

## Westinghouse Electric Corp.

**Model: H-126**

**Chassis:**

**Year: Pre 1948**

**Power:**

**Circuit:**

**IF:**

**Tubes:**

**Bands:**

### Resources

**Riders Volume 15 - WESTINGHOUSE 15-8**

**Riders Volume 15 - WESTINGHOUSE 15-9**

**Riders Volume 15 - WESTINGHOUSE 15-10**

**Riders Volume 20 - CHANGES 20-15**

WESTINGHOUSE ELECTRIC CORP.

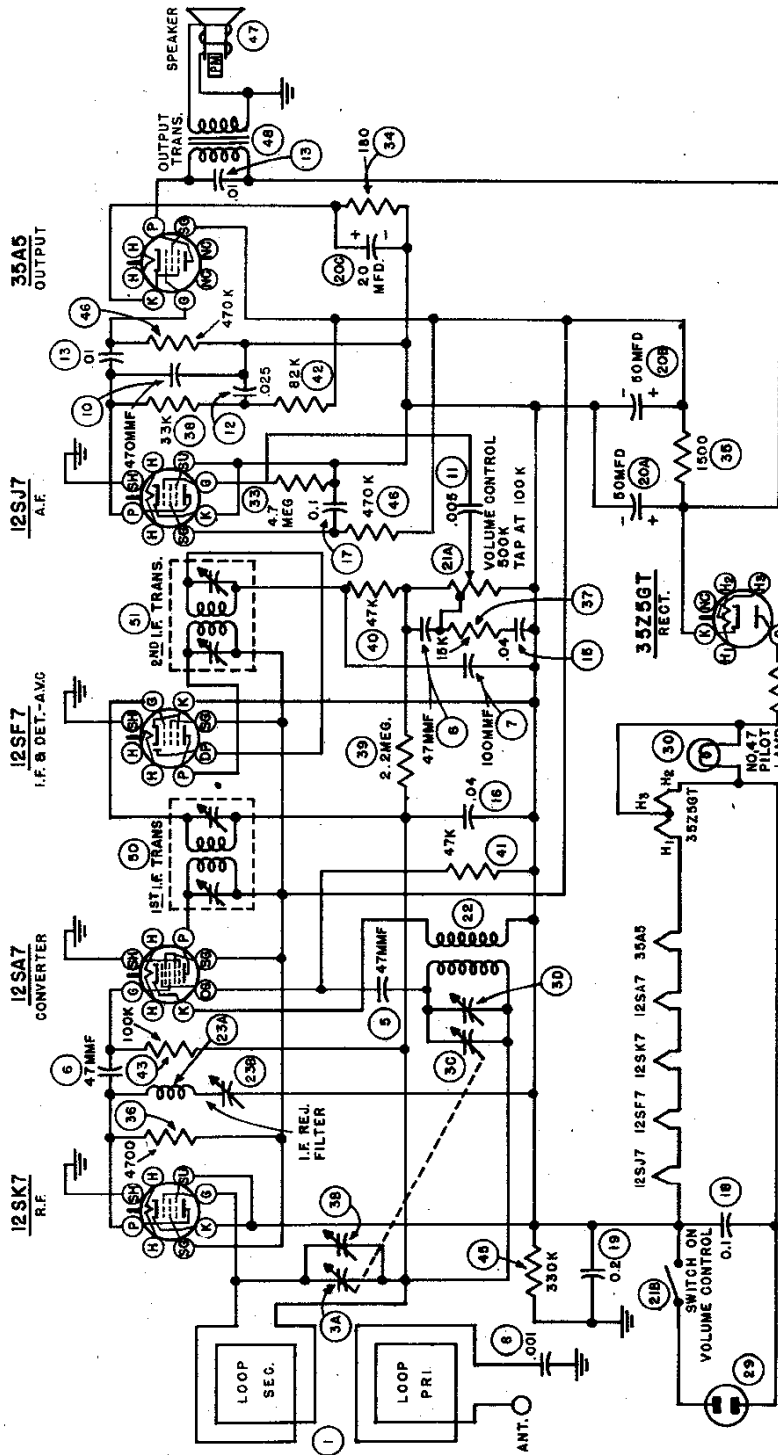

**RESISTANCE TABLE**

ITEM	PRIMARY OHMS	SECONDARY OHMS	REMARKS
1		2	
22	$\frac{1}{2}$	7	
23A	50		
50	27	26	
51	27	23	
47		2.95	VOICE COIL DISCONNECTED
48	375	$\frac{1}{4}$	VOICE COIL DISCONNECTED

INTERMEDIATE FREQUENCY : 455 KC

**VOLTAGE AND CURRENT TABLE**  
 ALL VOLTAGE READINGS ARE MEASURED FROM THE NEGATIVE SIDE OF THE BATTERY FILTRES UNLESS OTHERWISE SPECIFIED. 20,000 OHMS PER VOLT METER LINE VOLTAGE IS 117 V.A.C. SIGNAL VOLTAGE IS ZERO.

TUBE	SOCKET	TERMINAL	1k mc
12SK7	ZERO	70 31	
12SA7	ZERO	70 69	
12SF7	ZERO	70 69	
12SJ7	ZERO	19 26 0 9	
35A5	4.25	70 115 24 0	
35Z5GT	122		52.0

READINGS SHOULD APPROXIMATE THE ABOVE WITHIN 20 PERCENT.

**Loudspeaker:**

Type ..... 5" dia. P.M. dynamic  
 V.C. Impedance ..... 3.2 ohms at 400 cps

**Power Output:**

Undistorted ..... 0.85 watt  
 Maximum ..... 1.25 watts

WESTINGHOUSE ELECTRIC CORP.

to 1615 kc. Tune the receiver tuning condenser to minimum. Adjust the trimmer on the oscillator section of the main tuning condenser for **maximum** reading on the output meter.

12. Adjust the signal generator to 1400 kc. Bring the output lead near the receiver input but do not make an actual connection. Tune in the test signal on the receiver dial and adjust the antenna trimmer for maximum output as read on the output meter.

The foregoing alignment procedure is condensed in the following table as a convenience for the service technician:

Steps	Connect Signal Generator to—	Adjust Signal Generator to—	Tune Radio Dial to—	Adjust for Maximum Output
1	12SF7 grid in series with a .01 mfd. capacitor	455 kc	quiet point near 1600 kc.	Primary and secondary 2nd i-f transformer
2	12SA7 grid in series with a .01 mfd. capacitor	455 kc	quiet point near 1600 kc.	primary and secondary 1st i-f transformer
3	12SA7 grid in series with a .01 mfd. capacitor	455 kc	quiet point near 1600 kc.	repeat 1 and 2
4	antenna terminal	455 kc	600 kc	adjust i-f rejection trimmer for minimum output
5	antenna terminal in series with a 50 mmfd. capacitor	1615 kc	gang at minimum	oscillator trimmer
6	radiated signal from signal generator	1400 kc	1400 kc	adjust antenna trimmer

**Power Supply Polarity:**

When the receiver is operated on 110 volts 60 cycles a.c., a slight hum may be heard if the power plug is inserted in such a manner that the "hot" side of the supply line is connected nearest to the chassis. To eliminate this trouble, reverse the supply plug in the convenience outlet.

When operated on direct current, the set will not function at all if the power plug polarity is reversed with respect to the line voltage. If it does not operate within one minute after it is turned on, reverse the plug in the convenience outlet.

**Tube Replacement:**

When replacing tubes this procedure must be followed to prevent damage to the loop and other delicate parts:

1. Disconnect the power plug from the 110-volt service outlet.
2. Pull the knobs and remove the Phillips head screw from the right-hand plastic cover.
3. Carefully remove the plastic cover and handle.
4. Lift the loop assembly and tilt it forward until the tubes are accessible.
5. Turn the tuning dial to 550 kc to avoid damage to the rotor plates of the tuning condenser.

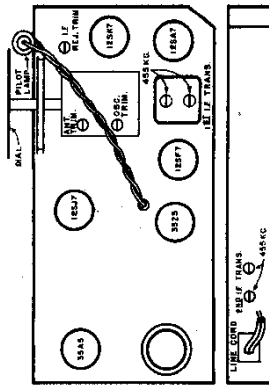

Fig. 1

**Alignment Procedure** (Refer to Fig. 1):

The overall sensitivity and selectivity of the Little Jewel are affected to a great extent by the alignment of the i-f and r-f circuits. In general, a complete realignment of both circuits is unnecessary. If realignment is required, however, the following procedure is recommended:

1. Remove the knobs, the plastic cover, and the loop as outlined above.
2. Remove the Allen head screw from the left-hand plastic cover and carefully lift off the cover.
3. Turn on the receiver and tune to a quiet spot near 1600 kc.
4. Connect an a-c output meter across the speaker voice coil. Turn the meter range switch to a high-voltage position.
5. Connect the outer conductor of the signal generator test lead to the common negative (this is the metal can enclosing the filter capacitors). Reduce the output of the signal generator to prevent a.v.c. action during the alignment procedure.
6. Connect the inner conductor of the signal generator test lead to the 12SF7 i-f amplifier control grid through a capacitance of 0.01 mfd. Adjust the signal generator frequency to 455 kc.
7. With an insulated screwdriver or neutralizing tool, adjust the second i-f transformer secondary trimmer for maximum reading on the output meter. Use the lowest practicable scale on the meter and, as the circuits come into alignment, reduce the signal generator output to prevent a.v.c. action.
8. Repeat operation 7, this time adjusting the second i-f transformer primary trimmer.
9. Connect the signal generator output, through the 0.01 mfd. capacitor, to the control grid of the 12SA7 converter tube. Repeat operations 7 and 8, this time adjusting the secondary and primary trimmers of the **first** i-f transformer.
10. Connect the signal generator output, adjusted to 455 kc, to the antenna terminal at the bottom of the cabinet. Tune the radio dial to 600 kc. Adjust the i-f rejection trimmer for **minimum** reading on the output meter.
11. Connect the test oscillator output through a capacitance of 50 mmfd. to the antenna terminal at the bottom of the cabinet. Adjust the signal generator frequency



WESTINGHOUSE ELECTRIC CORP.

PARTS LIST FOR H-125 AND H-126

When ordering parts specify model number of set in addition to part number and description of part.

Item No.	Part No.	Description of Part
1	V-3465	Loop antenna
3	V-3474	Capacitor, variable
3A		Capacitor, antenna tuner
3B		Capacitor, antenna trimmer
3C		Capacitor, oscillator tuner
3D		Capacitor, oscillator trimmer
5	RCM20A470K	Capacitor, 47 mmfd.
6	RCM20A470M	Capacitor, 47 mmfd.
7	RCM20A101M	Capacitor, 100 mmfd.
8	RCPI0W6102A	Capacitor, 1000 mmfd.
10	RCM20A471M	Capacitor, 470 mmfd.
11	RCPI0W6302A	Capacitor, .005 mfd.
12	RCPI0W2253K	Capacitor, .025 mfd.
13	RCPI0W2103A	Capacitor, .01 mfd.
15	RCP10W2403K	Capacitor, .04 mfd.
16	RCP10W2403A	Capacitor, .04 mfd.
17	RCP10W2104A	Capacitor, .10 mfd.
18	RCP10W4104A	Capacitor, .10 mfd.
19	RCPI0W2204A	Capacitor, .20 mfd.
20	V-3470	Capacitor, electrolytic
20A		Capacitor, 50 mfd. 150 volts electrolytic
20B		Capacitor, 50 mfd. 150 volts electrolytic
20C		Capacitor, 20 mfd. 25 volts electrolytic
21	V-3476	Control, volume and switch
21A		Control, variable resistor
21B		Control, switch
22	V-3473	Coil, oscillator
23	V-3465	Coil, trap assembly
23A		Coil
23B		Trap trimmer
29	V-3477	Cord, power A.C.
30		Light, pilot
31	RC20AE270K	Resistor, 27 ohms 0.5 watt
33	RC20AE475M	Resistor, 47 megohms 0.5 watt
34	RC20AE181J	Resistor, 180 ohms 0.5 watt
35	RC30AE152K	Resistor, 1500 ohms 1 watt
36	RC20AE472K	Resistor, 4700 ohms 0.5 watt
37	RC20AE153K	Resistor, 15,000 ohms 0.5 watt
38	RC20AE333K	Resistor, 33,000 ohms 0.5 watt
39	RC20AE225M	Resistor, 22 megohms 0.5 watt
40	RC20AE473M	Resistor, 47,000 ohms 0.5 watt
41	RC20AE473K	Resistor, 47,000 ohms 0.5 watt
42	RC20AE823K	Resistor, 82,000 ohms 0.5 watt
43	RC20AE104K	Resistor, 100,000 ohms 0.5 watt
44	RC20AE334M	Resistor, 330,000 ohms 0.5 watt
46	RC20AE474K	Resistor, 470,000 ohms 0.5 watt
47	V-3475	Speaker, 5 inch permanent magnet
48	V-3496	Transformer, 1st i-f
50	V-3471	Transformer, 2nd i-f
51	V-3219S-1	Cord, dial drive

V-3455-1	.....Dial (for Model H-125 only)
V-3455-2	.....Dial (for Model H-126 only)
V-3449	.....Drive shaft bearing
V-3480	.....Shaft, drive
V-3468	.....Socket, molded octal tube
V-3469	.....Socket, molded octal tube (shielded)
V-3499	.....Socket, pilot light
V-3448	.....Spring, dial drive
V-3435	.....Bumper, felt (screw type)
V-3501-1	.....Case assembly, center
V-3461-1	.....Cover, left-hand (H-125 only)
V-3459-1	.....Cover, right-hand (H-125 only)
V-3498-1	.....Handle assembly (H-125 only)
V-3481-1	.....Knob (H-125 only)
V-3491	.....Terminal strip assembly
V-3461-2	.....Cover, left-hand (H-126 only)
V-3459-2	.....Cover, right-hand (H-126 only)
V-3498-2	.....Handle assembly (H-126 only)
V-3481-2	.....Knob (H-126 only)
V-3711-1	.....Baffle and Grille Cloth Assembly (H-125)
V-3333S-1	.....Baffle and Grille Cloth Assembly (H-126)
V-3333S-2	.....Medallion (H-125 only)
V-3745	.....Medallion (H-126 only)
	.....Socket, lock-in

SUBJECT: CIRCUIT CHANGE, H-125 and H-126 Radios

Effective July 11, 1946, all Model H-125 and H-126 radios which have the letter "CH" stamped on the end of the chassis directly below the output tube, have been changed as follows:

A 470 ohm 1/4 watt isolating resistor has been inserted in the plate and screen supply line for the R.F. and converter stages, and a .02 mfd, 200 volt paper by-pass capacitor has been connected from the tube side of this resistor to the common negative line. These connections are shown below.

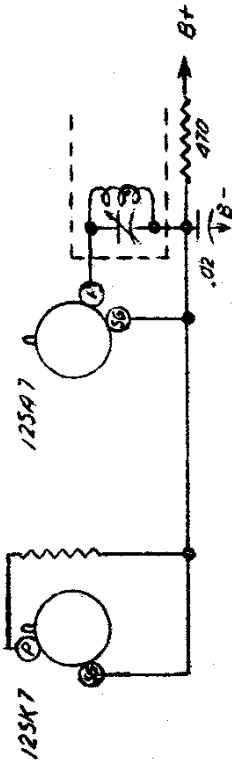

Where this change has been incorporated in the radio, voltages at the R.F. and converter tube sockets will differ slightly from the values given in the original Service Notes. Approximate voltages when the change is incorporated are as follows: 125K7 screen grid 66 V., plate 30 V.; 125A7 screen grid 66 V., plate 65 V.

Procurement difficulties with respect to certain components make the change advisable at this time.

**Tele-Tone Chassis A**

Models 123, 125, 127, and 131 are the same as Model 100, Chassis A, which appears on page 15-2 of *Rider's Volume XV*.

**Tele-Tone Chassis D**

Models 110, 119, 124, 126, and 132 are the same as Model 117, Chassis D, appearing in *Rider's Volume XV*, page 15-4.

**Tele-Tone Chassis U**

Models 172 and 176 are the same as Model 156, Chassis U, which appears on page 17-4 of *Rider's Volume XVII*.

**Tele-Tone Chassis W**

Models 154, 155, 173, and 177 are the same as Model 152, Chassis W, which appears on pages 17-2 and 17-3 of *Rider's Volume XVII*.

**Templetone H-127**

This model is the same as Model G-725, appearing on pages 17-3 through 17-6 of *Rider's Volume XVII*.

**United Motors 982421**

This model appears on pages 19-44 through 19-49 of *Rider's Manual Volume XIX*. The following service parts have been changed after serial #1-38500.

Illus. No.	Production Part No.	Service Part No.	Description
6	1219508	1219508	1st i-f coil assy.
7	1219509	1219508	2nd i-f coil assy.
25	7240724	M908	Electrolytic
25A			20 $\mu$ f, 25 v.
25B			20 $\mu$ f, 400 v.
25C			20 $\mu$ f, 400 v.
28	7237836	E202	0.002 $\mu$ f, 600 v. tubular
48	1213217	A101	100 ohms, 1/2 w.
	1218107	5233	6SR7
	1213793	5241	6V6GT
	7237751	5229	6SR7
	7237752	5222	6SA7

**Watterson RC-4581**

This model is the same as Model 4581 appearing on page 15-1 of *Rider's Volume XV*.

**Western Auto D2718 Series B, Serial No. 137000 Up**

This model is the same as Model D2718, appearing on pages 17-20 through 17-23 of *Rider's Volume XVII*, except for the following changes. Capacitor C30, formerly connected from the junction of R-16, C-29, and pin 8 of the 12SQ7 tube to pin 2 of the 35Z5GT rectifier tube, is connected from the same junction to the center tap (pin 3) of the filament of the 35Z5GT rectifier tube.

The part number of capacitor C16 and C20 should be changed from 47X446 to 47X466. The value remains the same. Part number 17X96, celluloid crystal, should be added to the parts list.

**Western Auto D4832-B**

This model appears on pages 18-69 through 18-72 of *Rider's Volume XVIII*. The "B" chassis of this model differ from the "A" chassis by a change in the value of resistor R-4 from 220,000 ohms to 10,000 ohms.

The new part number and description are as follows:

R-4 B-85103 10,000 ohms, 0.5 w.

**United Motors R-705**

This model appears on pages 17-1 through 17-6 of *Rider's Volume XVII*. This receiver may be installed in the 1949 Fords by using parts from the adapter parts package number 4428. It is necessary to use the Delco universal speaker, part number 6111—6" x 9" elliptical speaker, in place of the speaker supplied with the radio set. This speaker should be returned to your stock under part number 6104.

The parts that are to be used from adapter package 4428, are shown in the following operations.

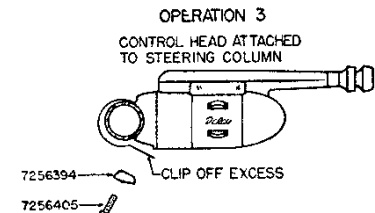
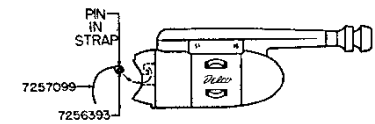
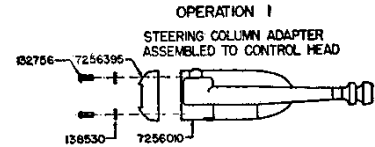

OPERATION 4: Remove the tips from speaker cable and solder ends to 6" x 9" speaker terminals.

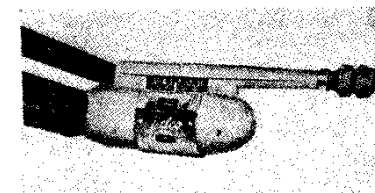
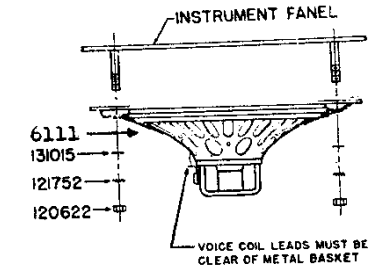
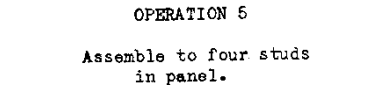

The various operations necessary to install United Motors Model R-705 in the 1949 Fords, as well as the assembled control head are illustrated.

**Westinghouse H-125, H-126, H-127**

Models H-125 and H-126 appear in *Rider's Volume XV*, pages 15-8 through 15-10. Several changes were made in the chassis of these two models in late production. A 35L6GT output tube replaces the 35A5. The electrical characteristics of the tubes are similar except for a difference in tube bases and connections. An isolating network consisting of a 470-ohm resistor (44) and a 0.02- $\mu$ f capacitor (14) has been inserted in the plate and screen voltage supply line for the r-f and converter stages. In the circuit, the rotor plates of the tuning and trimmer capacitors are now connected directly to chassis ground rather than to the AVC line.

Model H-127 is the same as the previous models with a burgundy and gold cabinet. The following items should be added to the parts lists for these models:

- 14 RCP10W2203A Capacitor, 0.02  $\mu$ f
- 44 RC20AE471M Resistor, 470 ohms 0.5 watt
- V-3711-2 Case Assembly, center (H-126 and H-127)
- V-3991 Cover, left hand (H-127)
- V-3992 Cover, right hand (H-127)
- V-3498-2 Handle Assembly (H-127)
- V-3481-2 Knob (H-127)
- V-3333-2 Medallion (H-127)
- V-3455-2 Dial (H-127)

**Westinghouse H-164, H-166, H-166A, H-167**

These models appear on pages 18-12 through 18-19 of *Rider's Volume XVIII*.

To reduce hum in later production of these models, a de-coupling network was inserted in the plate circuit of the 6AT6 a-m detector, avc and a-f amplifier tube. This network consists of a 100,000-ohm 1/2 watt resistor (RC20AE104K) and a 0.1  $\mu$ f 400 volt resonant type capacitor (V-5442-1). The resistor is inserted between the plate load resistor (R11) and the B plus line, and the capacitor is connected from the junction of R11 and the new resistor to ground.

**Westinghouse H-183, H-183A**

These models appear on pages 19-15 through 19-17 of *Rider's Manual Volume XIX*. An error exists in the schematic diagram. The value of R9 in the converter circuit should be 3,300 ohms instead of 300 ohms.

The position of C20 in the circuit has been changed. On some chassis this capacitor was connected across the primary of the output transformer as shown on the schematic diagram. In later production, the capacitor is connected from the plates to the cathodes of the parallel 25L6GT output tubes.

**Westinghouse H-186, H-187**

These models appear on pages 18-26 through 18-30 of *Rider's Volume XVIII*.

To reduce hum in later production of these models, a de-coupling network was inserted in the plate circuit of the 6AT6 AM detector, AVC and A-F amplifier tube. This network consists of a 100,000 ohm 1/2 watt resistor (RC20AE104K) and a 0.05  $\mu$ f 400 volt capacitor (RCP10W4503A). The resistor is inserted between the plate load resistor (R13) and the B plus line, and the capacitor is connected from the junction of R13 and the new resistor to ground.